



ZRT-3PDIL / ZRT-3PDIL-HP

THREE PARALLEL DAMPER IN-LINE ZONE TERMINAL

Description

ALDES Three Parallel Damper In-Line Zone Terminals (ZRT-3PDIL) and High-Pressure Three Parallel Damper In-Line Zone Terminals (ZRT-3PDIL-HP) are designed to introduce flexibility and dynamic control to central ventilation systems. Used in both large and small systems, the ZRT-3PDIL/ZRT-3PDIL-HP controls ventilation where it is required without the need for individual fans. Each ZRT-3PDIL/ZRT-3PDIL-HP is a combination of control dampers and constant airflow regulators. This unique combination provides the ability to select between low-flow, medium-flow, and high-flow ventilation rates without the need for expensive pneumatic, electronic, or DDC control systems.

The ZRT-3PDIL/ZRT-3PDIL-HP can be used in a supply or exhaust configuration. Note the airflow direction shown in Figure 1 and the airflow direction labels on the unit. For ZRT-3PDIL models, operating range is 0.12 to 1.2 in. w.g. (30 to 300 Pa). For ZRT-3PDIL-HP models, the operating range is 0.4 to 2.8 in. w.g. (100 to 650 Pa).

The ZRT-3PDIL/ZRT-3PDIL-HP allows for a selection between a continuous, regulated low airflow rate (both dampers closed); an on-demand, regulated medium airflow rate (one damper opened); or an on-demand, regulated high airflow rate (both dampers opened).

With both motorized dampers unpowered (closed) a low-continuous amount of regulated airflow passes through the low-flow constant airflow regulator. When power is applied to one or both of the motorized dampers, the damper(s) open, and air passes through the low-flow constant airflow regulator as well as the constant airflow regulator(s) in the powered damper(s).

Mounting

The ZRT-3PDIL/ZRT-3PDIL-HP is intended to be installed in-line in a duct system. It is provided with four (4) hanging brackets that are suitable to suspend the unit with threaded rods (not included). See Figure 1. The unit should be installed in a location that provides clearance for the access plate.

Maintenance

All components of the ZRT-3PDIL/ZRT-3PDIL-HP are accessible through the opening provided by the access plate.

*U.S. Pat. No. 9,759,442

AIRFLOW & ZONE CONTROL



READ AND SAVE THESE INSTRUCTIONS

FIGURE 1 - MOUNTING

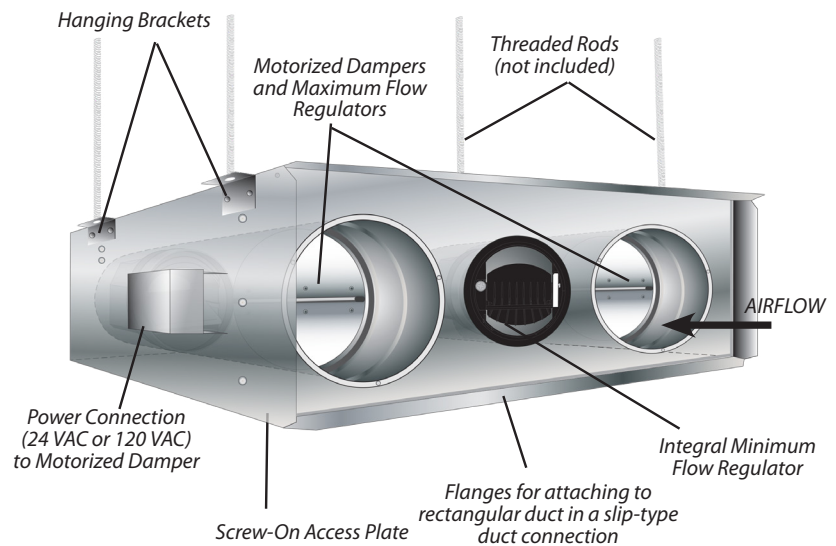

Wiring

ZRT-3PDIL/ZRT-3PDIL-HP wiring needs to meet all applicable electrical and building codes. If the electrical connections to the damper motor wiring boxes are not accessible after mounting, there needs to be enough slack (approximately 24") in the electrical wiring leading to the wiring boxes to allow the damper assemblies to be removed through the access opening. This will allow access to the electrical connections from the access opening.

ZRT-3PDIL/ZRT-3PDIL-HP models are available with 24 VAC or 120 VAC motorized dampers.

The two motorized dampers can be powered separately to allow for three distinct airflows (see Figures 3 and 5 on next page) or they can be powered in parallel for two distinct airflows (see Figure 2 and 4 on next page).

Warning

TO REDUCE THE RISK OF FIRE, ELECTRIC SHOCK, OR INJURY TO PERSONS, OBSERVE THE FOLLOWING:

1. Use this unit only in the manner intended by the manufacturer. If you have any questions, contact the manufacturer.
2. Before servicing or cleaning the unit, switch power off at service panel and lock service panel to prevent power from being switched on accidentally. When the service disconnecting means cannot be locked, securely fasten a prominent warning device, such as a tag, to the service panel.
3. Sufficient air is needed for proper combustion and exhausting of gases through the flue (chimney) of fuel-burning equipment to prevent backdrafting. Follow the heating equipment manufacturer's guidelines and safety standards, such as those published by the National Fire Protection Association (NFPA), and the American Society of Heating, Refrigerating and Air-Conditioning Engineers (ASHRAE), and the local code authorities.
4. In addition to the following manufacturer's instructions, it is necessary to comply with federal, state, and local government codes. Your purchase of this ALDES ventilation system represents an investment in the health and comfort of the occupants, as well as an investment in the protection of the building from the damaging effects of excessive indoor humidity.
5. Installation work and electrical wiring must be done by qualified person(s) in accordance with all applicable codes and standards, including fire-rated construction.
6. When cutting or drilling into wall or ceiling, do not damage electrical wiring and hidden utilities.
7. **WARNING** - To reduce the risk of fire, electric shock or injury, do not use replacement parts that have not been recommended by the manufacturer (e.g., parts made at home using a 3D printer).

Caution

1. For general ventilating use only. Do not use to exhaust hazardous or explosive materials and vapors.
2. Automatically operated device. To reduce the risk of injury, disconnect from power supply before servicing.

Satisfactory performance of a central ventilation system requires:

- Proper integration of all the components, compatible grilles, and wall/roof caps;
- Proper duct design for friction losses;
- Consideration of acoustic and vibration properties of the fan and its mounting;
- Acoustic properties of the grilles;
- Consideration of the mode of operation, whether continuous or automatically controlled by dehumidistat, timer, or occupancy sensor;
- Installation in a heated or unheated space, with consideration for the potential of condensation in the ducting or fan housing.

Inspect the carton upon receipt to ensure the terminal has not been damaged in transit. If damaged, it is the responsibility of the recipient to file a damage claim with the carrier. ALDES is not responsible for damage incurred during shipment.

Note: Prior to installation, inspect the terminal to ensure that damper(s) move freely and that the constant airflow regulators have not shifted during handling. Handle the unit with care to prevent damage to the housing and other components. Store the

