



### PLATE EXCHANGER

High-efficiency polymeric membrane counter-flow ERV

### CASING (Standard)

Material: 24-gauge galvanized steel  
Drain connections: optional  
Duct connections: 5" (127 mm)  
Insulation: EPS molded polystyrene  
Length: 23" (584.2 mm)  
Height: 19" (482.6 mm)  
Width: 16" (406.4 mm)  
Weight: 48 lb (22 kg)  
Exhaust Damper: Closed by gravity  
Swivel ports for horizontal, vertical, oblique or mixed installations.



### MOUNTING

Mounting chains included  
Wall mounting optional (P/N 699921)



### ELECTRICAL SPECIFICATIONS

120 V, 60 Hz, 139 W, 2.68 A



### FILTERS

(Standard)

Quantity:  
2 washable MERV 6 filters (P/N 699771)  
Optional filter types: MERV 8 (P/N 699772),  
MERV 13 (P/N 699881)



### SYSTEM COMPATIBILITY

Compatible with VentZone System

# InspirAIR® ELITE ERV

## EK150-TFX-V5

154 CFM at 0.4 in.w.g



UNIT

CORE



### BLOWERS & MOTORS

Two motorized impellers (backwards inclined)  
Quick-connect motors for easy and efficient maintenance  
EC motor



### DEFROST

Automatic Programmed Recirculation: Cycles are controlled by a temperature sensor when the outside temperature drops below 10.4°F (-12°C).

### WARRANTY

Limited 5 years on the cores and all covered components.

## WALL CONTROLS

Low voltage dry contact (24VAC) for interlock with heating and cooling systems. For more details, please refer to the wall control specification sheets.



Digital Multifunction Control (P/N 611242-FC)



LCD Electronic Multifunction Control (P/N 611227)



20/40/60 Minute Timer (P/N 611228)



Speed Control (Low/Intermittent/High)  
(P/N 611229)



Mode Control (Recirculation) (P/N 611230)

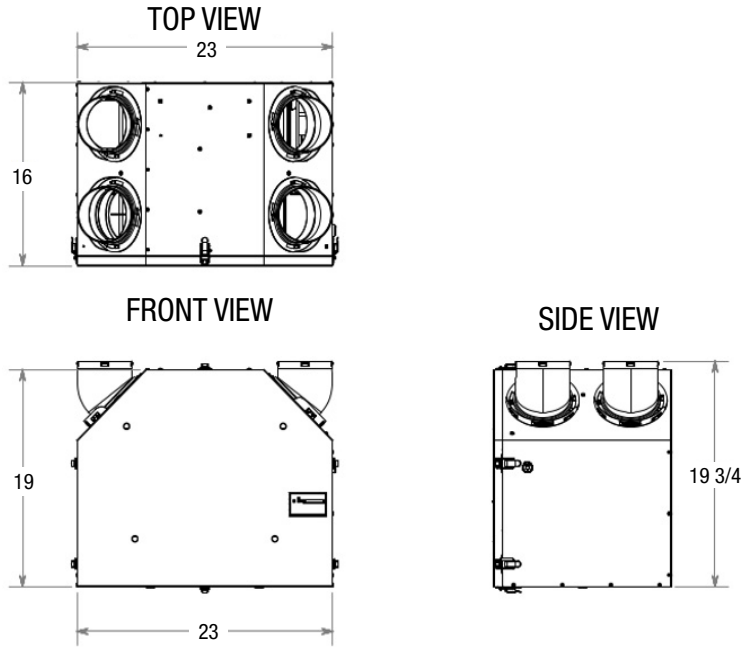

## EK150-TFX-V5: PERFORMANCE

### EK150-TFX-V5 Ventilation Performance

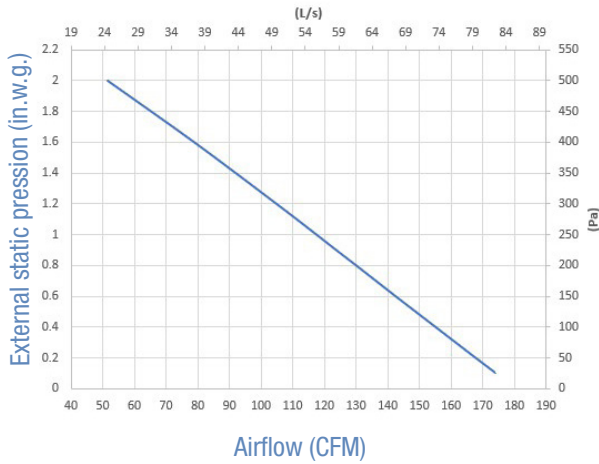

Thermal Performance – EK150-TFX-V5								
Supply Temperature		Net Airflow		Power Consumed (w)	Sensible Recovery Efficiency	Adjusted Sensible Recovery Efficiency	Latent Recovery/Moisture Transfer	Total Recovery Efficiency
°F	°C	CFM	L/s					
<b>Heating</b>								
32	0	50	23	23	83%	86%	74%	-
32	0	65	31	29	83%	86%	73%	-
14	-10	66	31	27	82%	84%	74%	-
<b>Cooling</b>								
95	35	65	31	29	-	-	88%	83%

Project:		Architect:	
Location:		Engineer:	
Model #:		Contractor:	
Quantity:		Comments:	
Submitted By:			
Date:			

For more information, contact your Aldes sales advisor, visit [aldes-na.com](http://aldes-na.com), call 1.800.255.7749, or find us on

