

# INSPIRAIR® COMPACT

## ERV

### E80-HF

ENERGY RECOVERY VENTILATOR  
74 CFM at 0.20 in.w.g (ESP)



UNIT

CORE

### PRODUCT DESCRIPTION

The energy efficient balanced in-suite ventilation solution ideal for multi-unit residential buildings, the E80-HF delivers superior heat recovery and a latent transfer of over 65% in a compact, easy-to-install package only 9 inches (230 mm) in height. Easily concealed in a drop-ceiling or soffit, this unit has been thoughtfully engineered for apartments, condominiums, and other dwellings.

The E80-HF exchanges **74 CFM** of air at 0.2 in.w.g (ESP), perfect for smaller dwellings in multi-unit residential buildings. The E80-HF includes Aldes' exclusive FLEXControl, electronic calibration that eliminates the need for balancing dampers and maximizes overall efficiency. Cold Supply Air Prevention (CSAP) stops air distribution to the dwelling for 135-minute cycles if the supply air temperature is below freezing, reducing the risk of damage to downstream equipment.



### Recovery Core

Material: High-latent-transfer (HLT) fixed plate enthalpic core

### Casing

Material: 24-gauge galvanized steel  
Drain Connection: None  
Duct Connections: 5" (127 mm)  
Insulation: 1" (25 mm)  
Width: 22" (559 mm)  
Height: 9" (230 mm)  
Height: 27" (686 mm)  
Weight: 37 lbs (17 kg); Shipping Weight: 42 lbs (19 kg)



### Mounting

Ceiling mount brackets (included) and optional chains (P/N 609051)



### Electrical requirement

120 VAC, 60 Hz, 0.8 A, 144W (MAX)  
Cord Set: 36" (914 mm) with ground



### Frost control

Automatic timed integral exhaust defrost.  
Cycles controlled by a temperature sensor when the outdoor temperature drops below 14°F (-10°C)



### Filters

Type : MERV 6 (Two replacement filters, P/N 612415)



### Blowers

Two motorized impeller (backward-inclined)

### KEY FEATURES

No drain required with Aldes' high performance HLT crossflow ERV core technology

Up to 73% sensible recovery efficiency, a great choice for LEED-certified buildings

Hassle-free balancing using the balancing chart, pressure taps in the door, and the independently adjustable supply and exhaust blowers (FLEXControl)

Unique compact door allows easy access to the washable MERV 6 filters

# DIMENSIONS

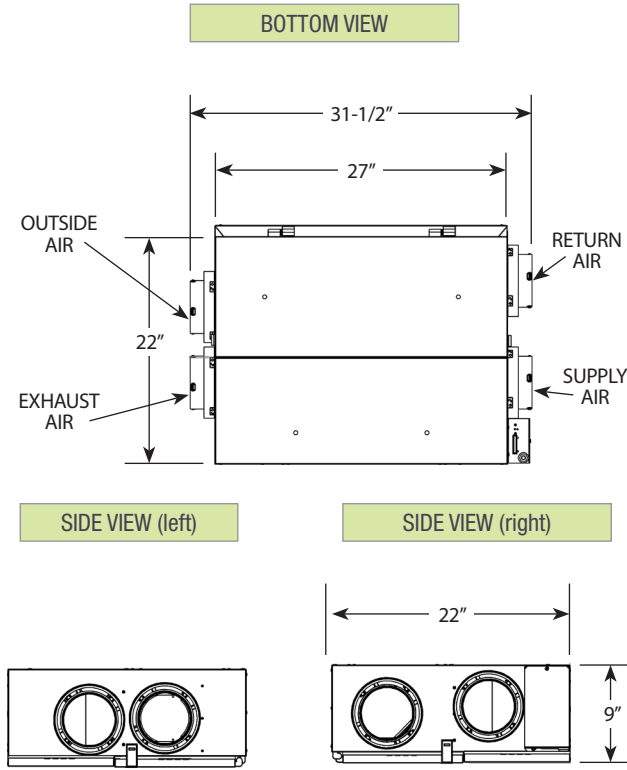

# CONTROLS

Low voltage dry contact (24VAC) for interlock with heating/cooling systems.

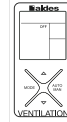

Digital Multifunction Control (P/N 611242-FC)

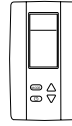

LCD Electronic Multifunction Control (P/N 611227)



20/40/60 Minute Timer (P/N 611228)



Speed Control (Low/Intermittent/High) (P/N 611229)

# PERFORMANCE

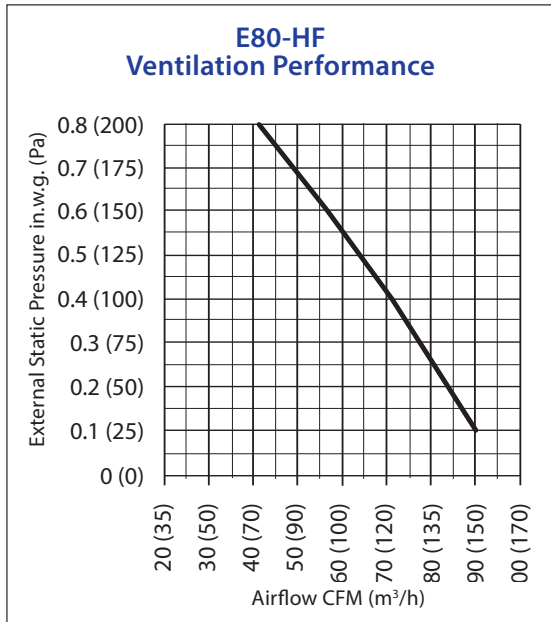

Recovery Performance – E80-HF

Supply Temperature		Net Airflow		Power Consumed (W)	Sensible Recovery Efficiency	Adjusted Sensible Recovery Efficiency	Latent Transfer	Total Recovery Efficiency
°F	°C	CFM	L/s					
32	0	55	26	32	73%	77%	0.61	--
32	0	68	32	54	70%	75%	0.59	--
32	0	81	38	66	68%	74%	0.55	--
95	35	49	23	30	--	--	0.66	64%

For more information, contact your Aldes sales advisor, visit [aldes-na.com](http://aldes-na.com), call 1.800.255.7749, or find us on



©2024 American ALDES Ventilation Corporation and ALDES Canada. All Rights Reserved. Reproduction or distribution, in whole or in part, of this document, in any form or by any means, without the express written consent of American ALDES Ventilation Corporation and/or ALDES Canada, is strictly prohibited. The information contained within this document is subject to change without prior written notice.

Corporation and/or ALDES Canada, is strictly prohibited. The information contained within this document is subject to change without prior written notice.