



InspirAIR® COMMERCIAL

PW40

Energy Recovery Ventilator

PRODUCT
SPECIFICATIONS
& TECHNICAL
DATA



*Interior Model

NOMINAL CAPACITY

2000 - 4000 CFM

PLATE EXCHANGER

Wheel (sensible and latent heat transfer)

CASING

(Standard)

- Double-wall cabinet
- 22-gauge galvanized steel interior and exterior
- Access doors with quarter-turn handles
- 22-gauge galvanized steel drain pan
- Drain Connections: 1" (25 mm) NPT
- Insulation: 1" (25 mm)

(Optional)

- Painted white baked enamel outside finish
- Removable access panels
- Supply and exhaust hoods with bird screens

MOUNTING (Standard)

- Standard Platform
- 18-gauge galvanized roof curb (insulation optional)

FROST PREVENTION/CONTROL (Optional)

See page 2 for details

ELECTRICAL & CONTROLS (Standard)

- 24V double motor contactor with start-stop dry contact
- Non-fused disconnect (NEMA 4)
- 24V transformer for controls
- Single point power

ELECTRICAL

- Non-Fused disconnect
 - » Optional Fused disconnect
- 24 VAC, 20 VA power available for accessories

WARRANTY

- Wheel Assembly: Limited 2-year
- All Other Covered Components: Limited 2-year



*Exterior Model

FILTERS

(Standard)

Quantity: 6 supply, 6 exhaust

Type: MERV 8

Dimensions: 16" x 20" x 2" (407 mm x 508 mm x 305 mm)

(Optional)

MERV 13 Filters (substitute on supply air circuit only)

BLOWERS & MOTORS

(Standard Options)

Blowers:

- Quantity: 2
- Forward-curved
- Permanently sealed and lubricated ball bearings
- Power transmission by adjustable pulleys and belts

Motors:

- Type: Inverter duty 10:1
- Maximum Power: 5 HP
- Available Voltages:
 - » 208, 230 V / 1ph / 60Hz
 - » 208, 230, 460, 575 V / 3ph / 60Hz

VARIABLE SPEED (Optional)

VFD:

- Quantity: 2 (1 per air stream)
- Blower Type: ODP or TEFC
- Permanently sealed and lubricated ball bearings

ECM:

- Quantity: 2 (1 per air stream)
- Plenum Type: Backward Inclined
- Permanently sealed and lubricated ball bearings
- Direct Drive
- Available Voltages:
 - » 208, 230, 460, 575 V / 3ph / 60Hz

PW40 Features (Continued)

FROST PREVENTION/CONTROL (Optional)

If no defrost mode is selected, it is the customer's responsibility to protect the wheel from freezing as needed.

Frost control activated by a temperature reference:
5°F (-15°C)

Internal Pre-Heat by Electric Coil:

- Powered by unit, SCR control (not available with 120 V)

Internal Pre-Heat by Hot Water Coil:

- 0-10 V signal on the control panel
- Piping connections under unit

Wheel Speed Variation:

- VFD on the wheel

Exhaust Defrost:

- Supply air blower shuts down and outside air damper closes. Warm exhaust air defrosts the wheel until it is free of obstruction.
- Includes motorized and insulated damper on fresh air intake (OA)

Recirculation Defrost:

- Exhaust air blower shuts down, outside air damper closes, exhaust air damper (optional) closes, and recirculation damper (included) opens. Warm exhaust air defrosts the wheel for a predetermined amount of time (see table at right).
- Includes motorized and insulated damper on fresh air intake (OA)

POST-HEAT COILS

Post-Heat by Electric Coil:

- Powered by unit, SCR control (not available with 120 V)
- 0-10VDC signal to maintain supply air temperature or 0-10VDC signal by others

Post-Heat by Hot Water Coil:

- 0-10VDC signal to maintain supply air temperature or 0-10VDC signal by others

OPTIONAL COMPONENTS

- Motorized and insulated damper for exhaust port (EA)
- Non-insulated backdraft damper for exhaust port (EA)
- Motorized and insulated damper on fresh air intake (OA) (included with exhaust and recirculation defrost)

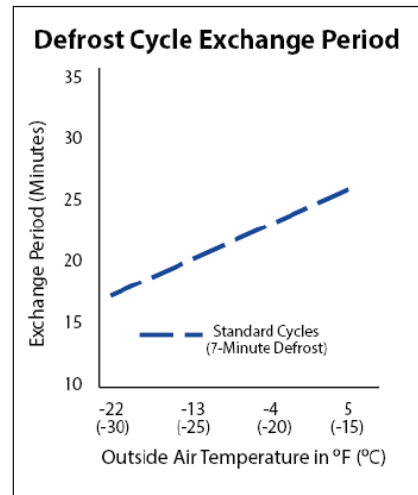

Wheel Performance

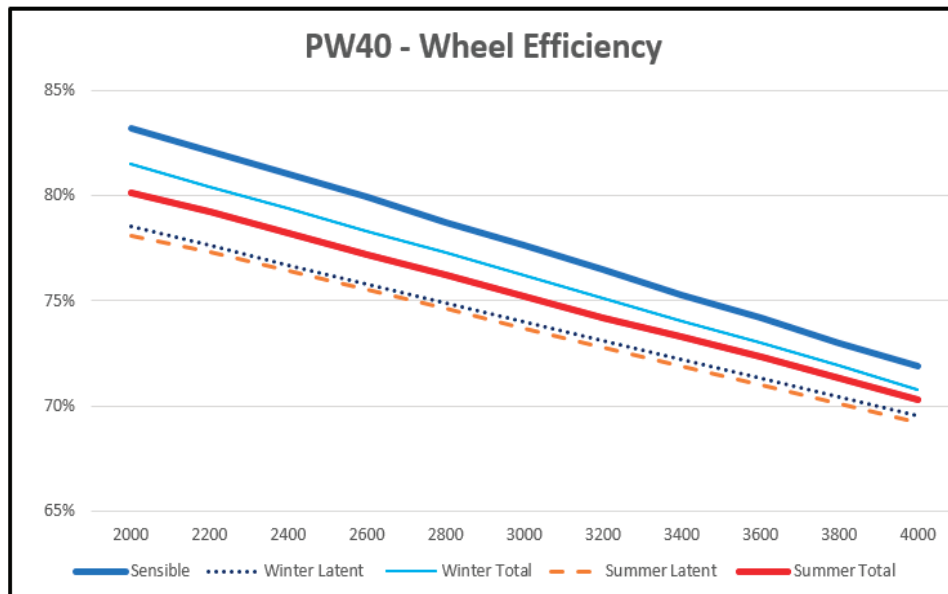

AHRI STANDARD CONDITIONS	CONDITIONS	
Outside Air Temperature	Winter	Summer
Dry Bulb	35°F (1.7°C)	95°F (35°C)
Wet Bulb	33°F (0.6°C)	78°F (25.6°C)
Exhaust Air Temperature	Winter	Summer
Dry Bulb	70°F (21.1°C)	75°F (23.9°C)
Wet Bulb	58°F (14.4°C)	63°F (17.2°C)

Note: Efficiencies are based on AHRI standard conditions.

PW40 Indoor Units Dimensions (Standard - inches)

Indoor Units

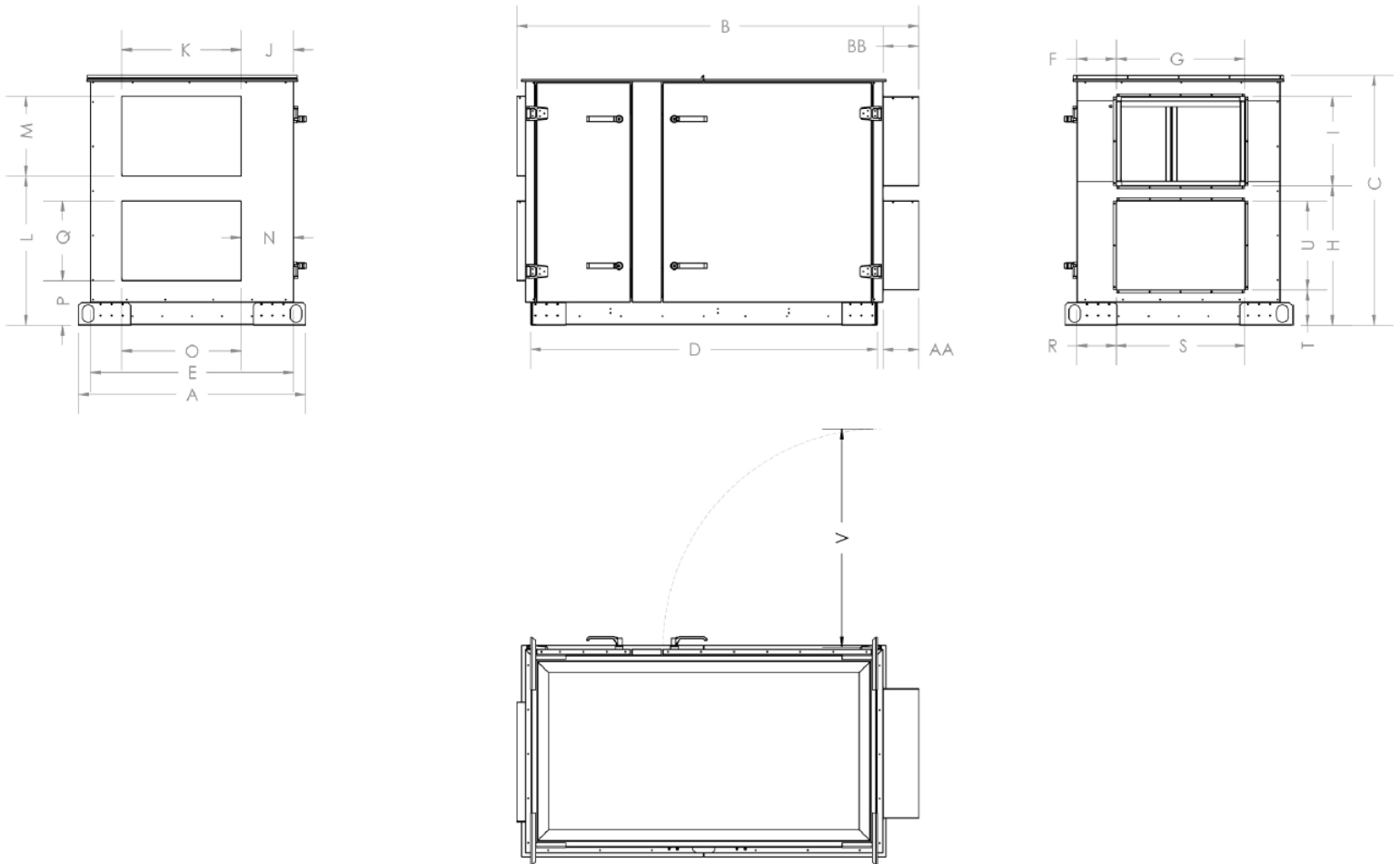

Dimension with Options (inches)												
A		B			C	D			E		F	
Overall	Bypass	Overall	1 Extension	2 Extensions		Overall	1 Extension	2 Extensions	Overall	Bypass	Overall	Bypass
57.5	N/A	91.5	111.5	N/A	60.75	80.5	100.5	N/A	50.5	N/A	7	N/A
G	H	I	J		K	L	M	N		O	P	Q
			Overall	Bypass				Overall	Bypass			
36.5	38.75	17.25	9.75	N/A	36.5	38.75	17.25	9.25	N/A	36.5	8.5	17.25
R		S	T	U	V	W	X	Y	Z	AA	AB	
Overall	Bypass											
7	N/A	36.5	8.5	17.25	40	N/A	N/A	N/A	N/A	7.5	7.5	

* 1 Extension is used when adding a Post-heat coil

PW40 Outdoor Units Dimensions (Standard - inches)

Outdoor Units

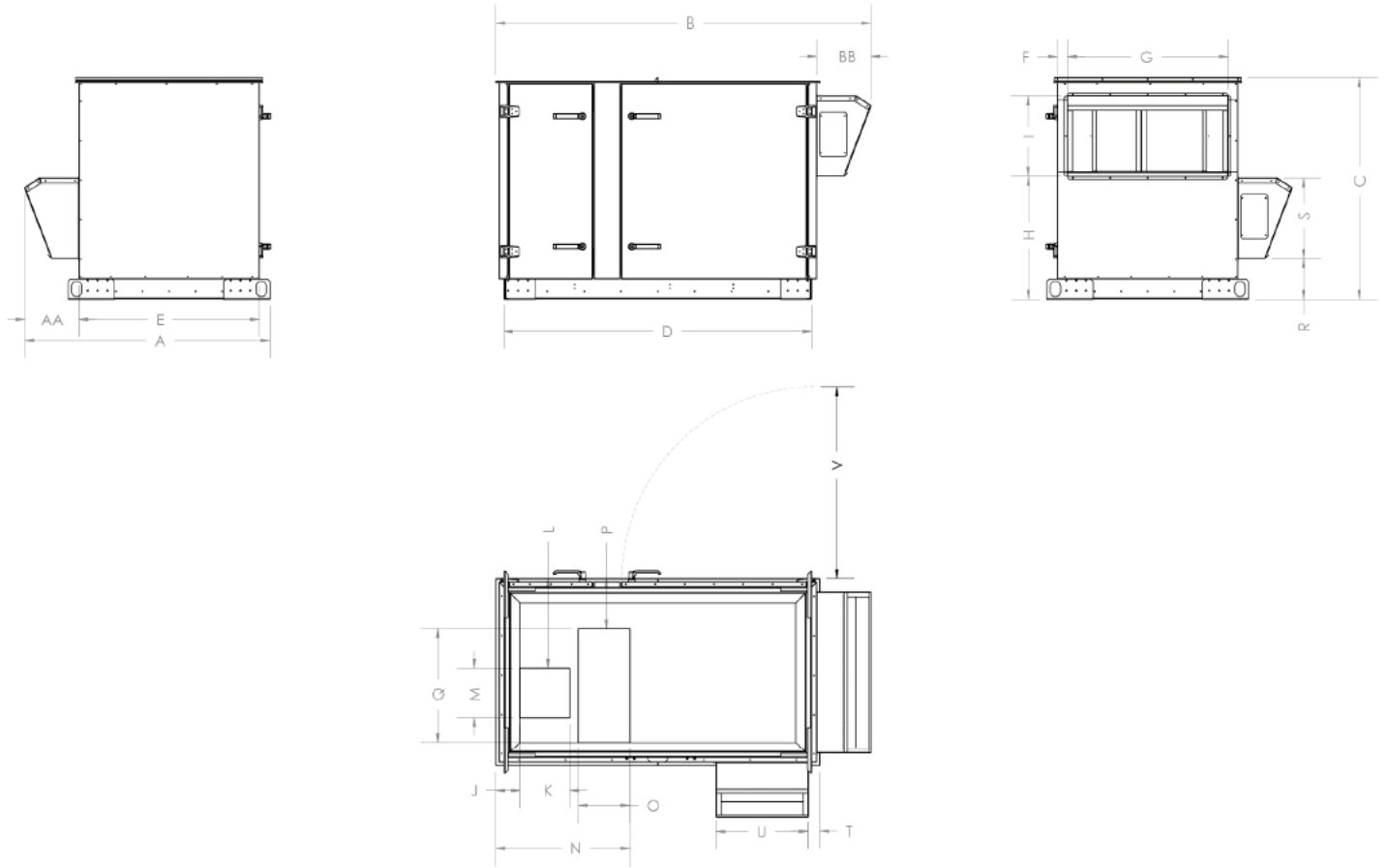

Dimension with Options (inches)												
A		B			C	D			E		F	
Overall	Bypass	Overall	1 Extension	2 Extensions		Overall	1 Extension	2 Extensions	Overall	Bypass	Overall	Bypass
66	N/A	94.25	114.25	N/A	60.75	80.5	100.5	N/A	50.5	N/A	2.5	N/A
G	H	I	J		K	L	M	N		O	P	Q
			Overall	Bypass				Overall	Bypass			
44	37.5	19.75	4	N/A	13.75	23.25	12.25	37.75	N/A	16	9	32.5
R		S	T	U	V	W	X	Y	Z	AA	AB	
Overall	Bypass											
10.75	N/A	16.25	1.75	18.75	40	N/A	N/A	N/A	N/A	11	11	

* 1 Extension is used when adding a Post-heat coil

PW40 Configurations & Weights

AVAILABLE CONFIGURATIONS
1-2-6-7
3-4-6-7
3-4-5-7

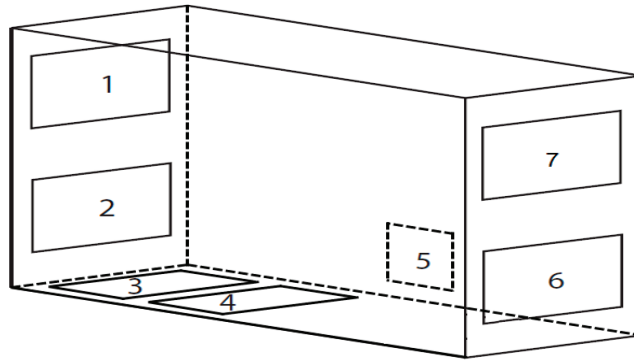

DUCT CONNECTION KEY	
1,3	Supply Air (SA)
2,4	Return Air (RA)
5,6	Exhaust Air (EA)
7	Outside Air (OA)

PW40 WEIGHTS & DIMENSIONS †	
Wheel Type	Wheel
Minimum Unit Weight	904 lbs (411 kg)
Maximum Unit Weight	1124 lbs (511 kg)
Minimum Shipping Weight	1009 lbs (459 kg)
Maximum Shipping Weight	1282 lbs (5583 kg)

† Actual weight may vary by ±10%.

PW40 Roof Curb Dimensions - inches

Dimensions with Options (inches)												
	SA	SB*	SC	SN	SO	SP	SQ	SR	SS	ST	SU	SZ
PW40	48	78	14	22	12.25	2.75	13.5	7.75	32.5	41.5	16	2

* Add 20" to width of Roof Curb for each extension

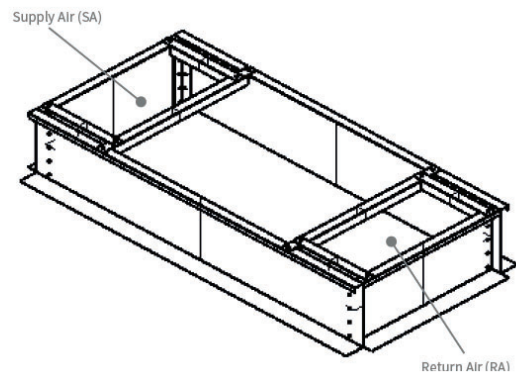
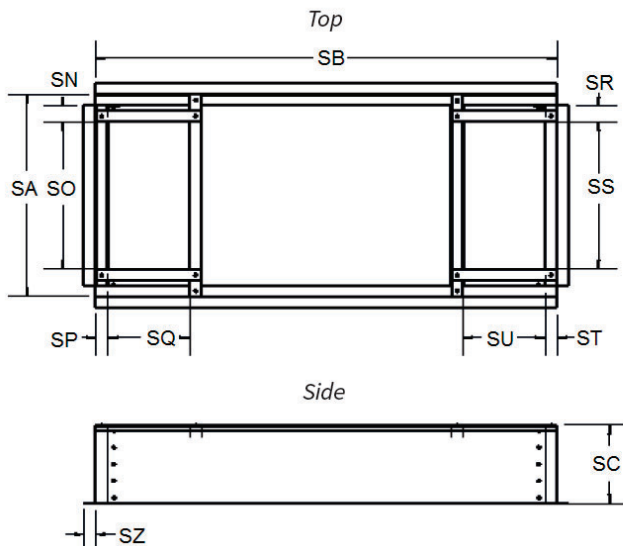

MODEL: PW40
SERIES: InspirAIR® Commercial
NOMINAL CAPACITY: 2000-4000

Standard Feature
 Optional Feature
(check the box to select this option)

REMEMBER TO: Send your completed selection to your American ALDES Representative.

UNIT

CABINET FINISH

- Galvanized
- Painted

DUCT CONFIGURATION

- 1-2-5-6 (Indoor Unit)
- 1-3-5-6
- 1-2-4-6
- 1-3-4-6 (Outdoor Unit)

CONFIGURATION OPTIONS

- None (Indoor Unit)
- Rooftop Installation (Outdoor Unit)
- Mirror Configuration*
(*Doors are located to the opposite side)

FROST CONTROL

- None
- Exhaust Defrost
- Recirculation Defrost
- Wheel Speed Variation
- Pre-Heat (Electrical Coil)
- Pre-Heat (Hot Water Coil)

HEATING OPTIONS

- None
- Post-Heat (Electrical Coil)
- Post-Heat (Hot Water Coil)

BLOWERS & MOTORS

MOTOR TYPE

- ODP
- TEFC

SPEED

- Single Speed
- ECM
- VFD

FILTERS

- MERV 8
- MERV 13

ELECTRICAL REQUIREMENTS

- 208V/1ph/60Hz
- 230V/1ph/60Hz
- 208V/3ph/60Hz
- 230V/3ph/60Hz
- 460V/3ph/60Hz
- 575V/3ph/60Hz

DISCONNECT

- Non-fused
- Fused

OPTIONAL ADD-ONS

- Motorized & Insulated Damper for OA
- Motorized & Insulated Damper for EA
- Non-Insulated Backdraft Damper for EA
- 24 VAC, 10 VA Terminals for OA and/or EA Dampers by Others
- 24 VAC, 20 VA Power Available for Accessories by Others
- Spare Filters QTY: _____
- Spare Belts QTY: _____
- Remote Display Panel
- Low Temperature Limit
- Dry Contact For Dirty Filter Alarm
- BacNET IP Controller
- BacNET MSTP Controller
- Phase-Loss Detection
- Fan Rotation Detection
- Carbon Dioxide Detection
- Relative Humidity Detection
- Free Cooling Management
- Independent Motor Management
- MERV 13 Filter Set (Replacement Filter)
- MERV 8 Filter Set (Spare Filter Set)
- Programmable Timer
- Removable Access Doors
- Wheel Rotation Detection Sensor
- Mechanical Purge